



MÁQUINA DE FEIJÃO

MACHINE FOR CEREALS

DS 100 | DS 180 | DS 200





CARACTERÍSTICAS TÉCNICAS

TECHNICAL FEATURES

Fácil Alimentação
do Produto

Easy product feeding

Turbina para aspiração
do pó residual

*Turbine for waste
dust extraction*

Pintura líquida
com tinta WEG

*Liquid paint with
WEG paint*

Produção de
150 à 200 sacas / h
*Production of 150 to
200 bags / h*

Proteções seguindo
as normas da NR 12
*Protections following
NR 12 standards*

Motorreductores SEW
Sew Gear Motors

Sistema de polimento
com até 4 polidores
*Polishing system with up
to 4 polishers*

Armação em aço
Steel frame

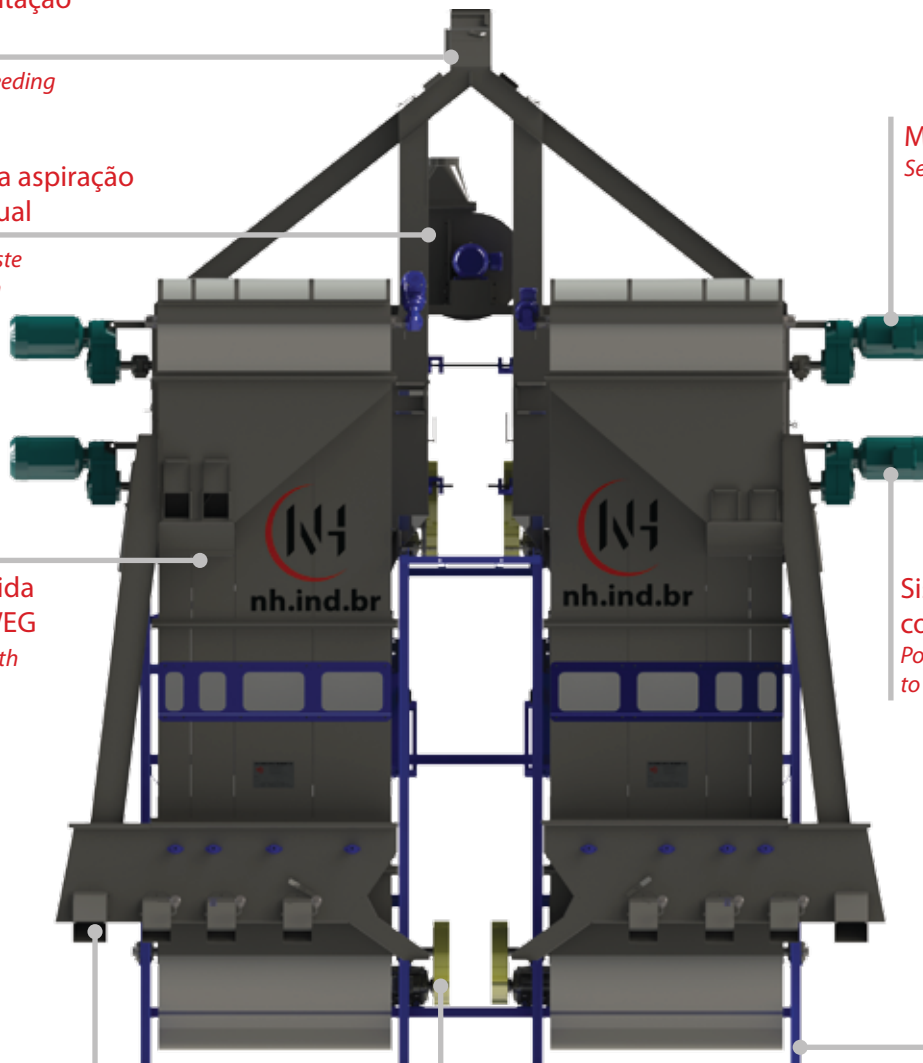



CARACTERÍSTICAS TÉCNICAS

TECHNIAL FEATURES

A Máquina para Feijão da Novo Horizonte é constituída pelo conjunto de uma coluna de classificação, polidores de escovas e peneiras vibratórias. Seu design arrojado e engenharia de alto rendimento transformaram a Máquina de Feijão Novo Horizonte em líder de vendas em todo território nacional. O desenvolvimento pioneiro do sistema de polimento garantiu qualidade e produtividade para todo o processo de beneficiamento, enquanto que a inclusão das peneiras vibratórias garante o repasse e, principalmente, a distribuição homogênea do fluxo do produto. E é assim, com a tecnologia 100% brasileira, que o nosso produto continua a conquistar o respeito e confiança de nossos parceiros, espalhados pelo Brasil e o mundo.

The Novo Horizonte Machine for Cereals consists of a set of sorting columns, brush polishers and vibrating screens. It's bold design and high-performance engineering have transformed the Novo Horizonte Machine for Pulses into a leader in sales throughout the country. The pioneering development of the polishing system ensured quality and productivity for the whole process of the beneficiation, while the inclusion of the vibrating screens guarantees the transfer and, mainly, the homogeneous distribution of the flow of the product. And it is with 100% Brazilian technology that our product continues to win the respect and trust of our partners, spread throughout Brazil and the world.

DS 100

DS 180

DS 200

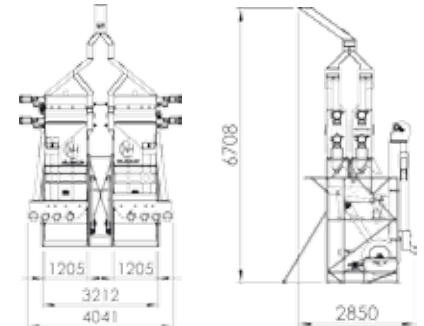
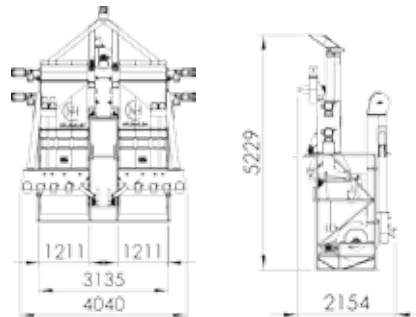
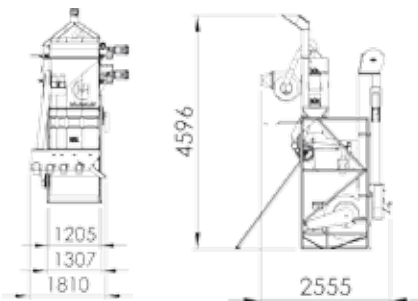

MODELO Model	100
CAPACIDADE Capacity (sacos/h) (bags/h)	60 à 120
POTÊNCIA Power (Motores Trif. 220/380 V) (Three-Phase Motors 220/380 V)	20,83 HP
PESO Weight	1.102 Kg

MODELO Model	180
CAPACIDADE Capacity (sacos/h) (bags/h)	120 à 200
POTÊNCIA Power (Motores Trif. 220/380 V) (Three-Phase Motors 220/380 V)	41,66 HP
PESO Weight	2.393 Kg

MODELO Model	200
CAPACIDADE Capacity (sacos/h) (bags/h)	150 à 250
POTÊNCIA Power (Motores Trif. 220/380 V) (Three-Phase Motors 220/380 V)	71,66 HP
PESO Weight	3.611 Kg

*OBS: Produção depende do peso específico do grão
*OBS: Production depends on the specific weight of the grain

*OBS: Produção depende do peso específico do grão
*OBS: Production depends on the specific weight of the grain

*OBS: Produção depende do peso específico do grão
*OBS: Production depends on the specific weight of the grain

EXEMPLO DE MONTAGEM

ASSEMBLY EXAMPLE

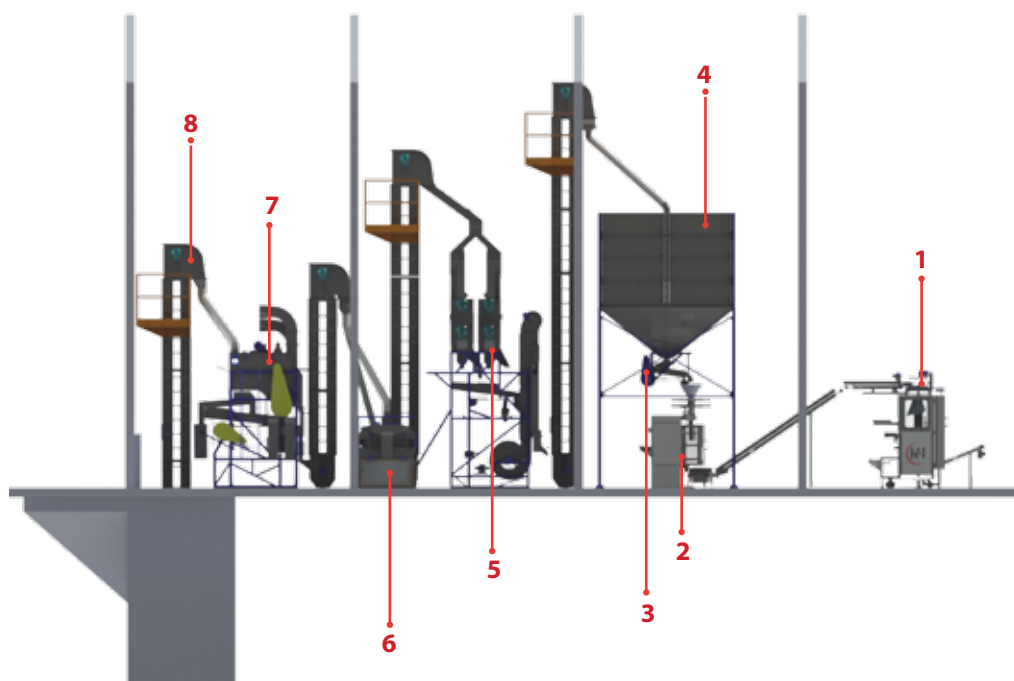

1. Enfardadeira Baler - ENF 30

2. Empacotadeira Packing Machine - EVA 1000

3. Bica de Jogo Output Grader - BSNH

4. Silo Silo

5. Máquinas de Feijão Machine for Cereals - DS 200

6. Separador de Pedras Destoner - SP 150

7. Pré-Limpeza Pre Cleaner - PNH 250

8. Elevador Elevator - ELNH 330

Aceitamos



Av. Dorival Faveri, 214 - Graminha

13481-604 - Limeira - SP

Fone: (19) 3451-2822

novo.horizonte@nh.ind.br

Consulte-nos

